

Power Receiver - RXS

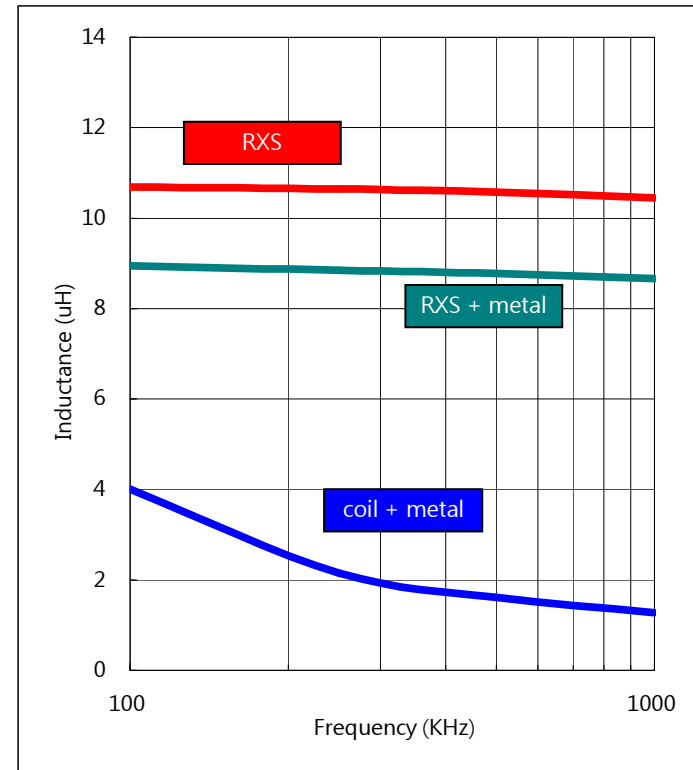
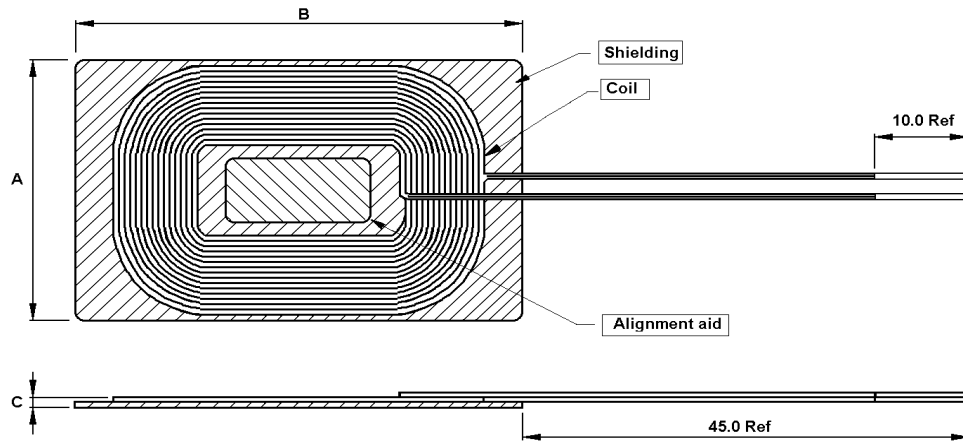
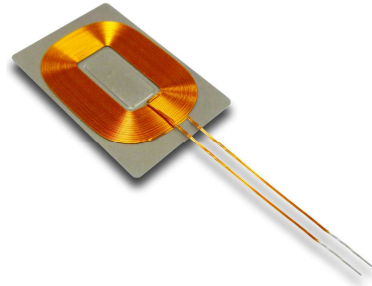

Dimension :

unit	mm
A	48.0 +- 0.4
B	32.0 +- 0.3
C	1.1 max

Electronic Characteristics :

L	10.8uH +- 10%
DCR	200 mΩ ref
Test Instruments :	Microtest 6377
Test Conditions :	100KHz / 1.0V / 0A